

DIMENSIONAL DATA - MODEL PTP

Propeller Units - Model PTP

Figure 17.1 - Dimensional Drawings

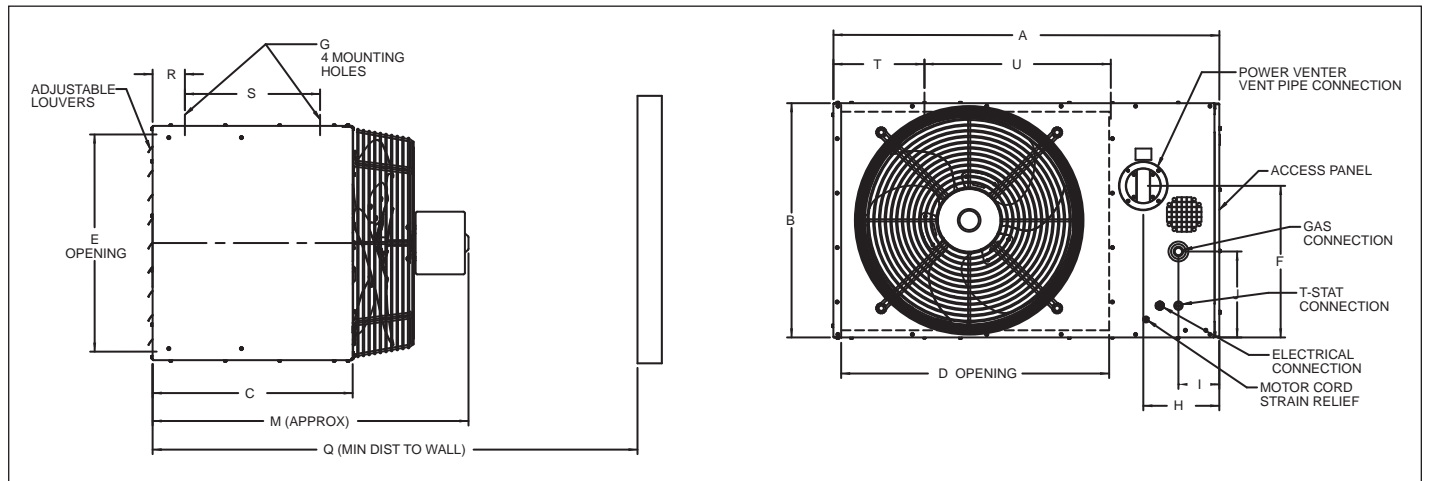

Table 17.1 - Dimensions (inches) - PTP ①

Models	PTP150	PTP175	PTP200	PTP250	PTP300	PTP350	PTP400
A	35.53	42.53	42.53	42.53	42.53	42.53	42.53
B	23.06	25.81	25.81	31.31	31.31	39.56	39.56
C	22.05	22.05	22.05	22.05	22.05	22.05	22.05
D	22.52	29.52	29.52	29.52	29.52	29.52	29.52
E	21.18	23.93	23.93	29.43	29.43	37.68	37.68
F	15.33	16.70	16.70	19.45	19.45	23.58	23.58
G (Mounting Hole) ②	3/8-16	3/8-16	3/8-16	3/8-16	3/8-16	3/8-16	3/8-16
H	8.37	8.37	8.37	8.37	8.37	8.37	8.37
I	4.50	4.50	4.50	4.50	4.50	4.50	4.50
M	31.79	32.83	34.43	33.83	33.83	34.83	34.83
Q ③	43.79	44.83	46.43	45.83	45.83	46.83	46.83
R	3.56	3.56	3.56	3.56	3.56	3.56	3.56
S	14.90	14.90	14.90	14.90	14.90	14.90	14.90
T	10.00	10.00	10.00	10.00	10.00	10.00	10.00
U	13.54	20.53	20.53	20.53	20.53	20.53	20.53
Gas Connection	1/2	1/2	1/2	3/4	3/4	3/4	3/4
Vent Connector Size	4"	4"	4"	6"	6"	6"	6"
Fan Diameter	20.00	22.00	22.00	22.00	22.00	24.00	24.00
Approx. Shipping Weight (lbs.)	165	210	220	265	270	310	320

① Do not use propeller units with duct work.

② Listed is the hole diameter and threads per inch to accept threaded rod.

③ Dimension equals overall plus 12".